

LIFTERS

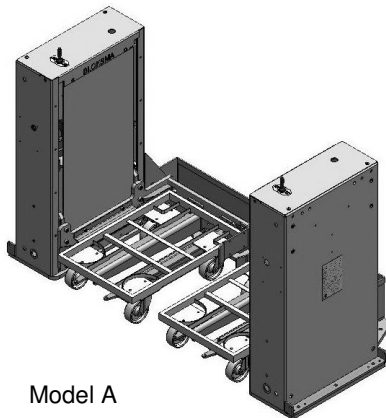

Model A

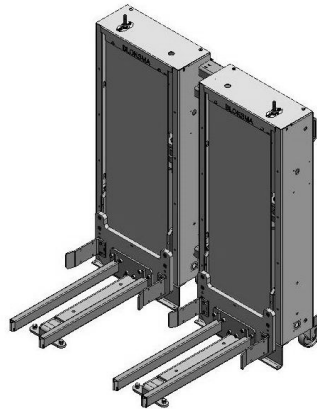

Model B

Pneumatic lifter HPS-T HPM-T

Tandem – Twin lifter
stationary / mobile

Suitable for Bloksma trolley BOF + BOZ
(see chapter TROLLEY)

Designed for ergonomic working at
assembly work stations and machines

Various load capacities available

Various load carriers available (forks,
platform, bracket or similar)

Adapted to the trolley to be loaded.

Standard control element

Hand lever on device

(options see Overview CONTROL
ELEMENTS)

Options:
automatic height adjustment etc.

Difference between
stationary / mobile
see overview MOBILITY

Item no.	Model	Load capacity per lifter	Size of trolley mm	Adaption of trolley / control element	Working height above floor level (GOK)
146599	B	200 kg each side	600 x 400 630 x 430	lengthside BOF + BOZ stationary - hand level	720 mm
146225	B	200 kg each side	600 x 400 630 x 430	lengthside BOF + BOZ stationary - hand level	920 mm
130754	B	300 kg each side	600 x 400 630 x 430	lengthside BOF + BOZ stationary - hand level	920 mm
145319	A	400 kg pro Seite	600 x 400 630 x 430	crossside BOF + BOZ stationary hand level on device	720 mm

Power demand: Pneumatic 6 bar

Other models / dimensions / loads as well as control elements on request.

The appearance of the device may deviate from the plotted models.